

CT4525
60 MHz High-Voltage Differential
Probe

User Manual

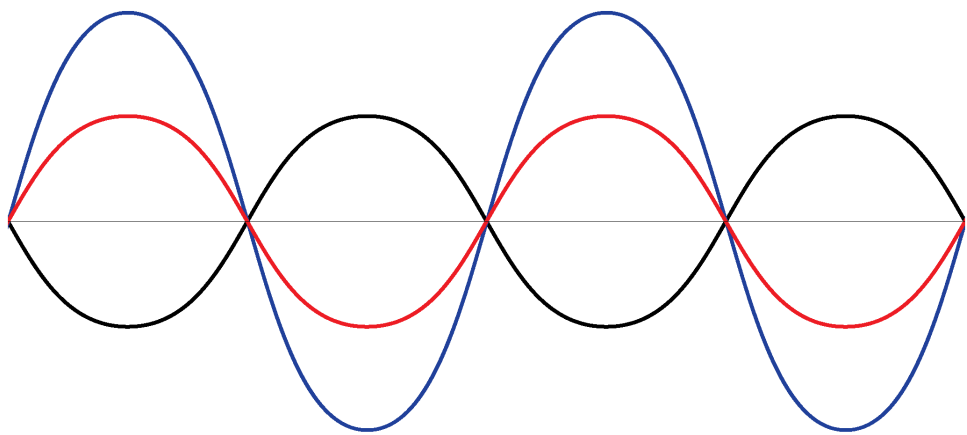

Notices

Copyright © Cal Test Electronics, Inc. All rights reserved.

Unauthorized duplication of this documentation material is strictly prohibited. Users are permitted to duplicate and distribute this documentation for internal educational purposes only. Cal Test Electronics is governed by United States and international copyright laws.

Made in Taiwan

User Manual Part Number

451-121-001

Available in electronic format only

Published by:

Cal Test Electronics, Inc.
22820 Savi Ranch Parkway
Yorba Linda, CA 92887 USA

Warranty

LIMITED TWO-YEAR WARRANTY

Cal Test Electronics, Inc warrants these products to be free from defective material or workmanship for a period of 2 years from the date of original purchase. Under this warranty, Cal Test Electronics, Inc is limited to repairing this product when returned to the factory, shipping charges prepaid, within the warranty period.

Units returned to Cal Test Electronics, Inc that have been subject to abuse, misuse, damage, or accident, or have been connected, installed, or adjusted contrary to the instructions furnished by Cal Test Electronics, Inc, or that have been repaired by unauthorized persons, will not be covered by this warranty.

Cal Test Electronics, Inc reserves the right to discontinue models, change specifications, price, or design of this device at any time without notice and without incurring any obligation whatsoever.

The purchaser agrees to assume all liabilities for any damages and/or bodily injury which may result from the use or misuse of this device by the purchaser, his employees, or agents.

THIS WARRANTY IS IN LIEU OF ALL OTHER REPRESENTATIONS OR WARRANTIES EXPRESSED OR IMPLIED AND NO AGENT OR REPRESENTATIVE OF CAL TEST ELECTRONICS, INC IS AUTHORIZED TO ASSUME ANY OTHER OBLIGATION IN CONNECTION WITH THE SALE AND PURCHASE OF THIS DEVICE.

Contents

Notices	2
User Manual Part Number	2
Warranty	2
Contents	3
Compliance Information	4
EMC	4
EC Declaration of Conformity - EMC	4
Safety	4
EC Declaration of Conformity - Low Voltage	4
Environmental	4
Restriction of Hazardous Substances (RoHS 2)	4
Product End-of-Life Handling	4
Terms & Symbols	5
Terms	5
Symbols	6
Safety Information	7
Safety Notices	7
IEC Measurement Category & Pollution Degree Definitions	11
Introduction	12
Overview	12
Supplied Accessories	14
Setting Up and Using the Probe	15
Setting Up	15
Using	15
Specifications & Characteristics	17
Performance Plots	19
Performance Verification	21
Required Equipment	21
Test Procedures	21
Test Setup	21
Gain Accuracy	22
Rise Time	23
Cleaning	24
China RoHS 2	25
Hazardous Substances Disclosure Table	25

Compliance Information

EMC

EC Declaration of Conformity - EMC

Compliance was demonstrated to the following specifications listed in the Official Journal of the European Communities: EMC Directive 2014/30/EU.

EN 61000-6-3. Electromagnetic compatibility (EMC) - Part 6-3: Generic standards - Emission standard for residential, commercial, and light-industrial environments.

EN 61000-6-1. Electromagnetic compatibility (EMC) - Part 6-1: Generic standards - Immunity for residential, commercial, and light-industrial environments.

Safety

EC Declaration of Conformity - Low Voltage

Compliance was demonstrated to the following specification as listed in the Official Journal of the European Communities: Low Voltage Directive: 2014/35/EU.

EN 61010-031:2015 Ed 2.0. Safety requirements for electrical equipment for measurement, control and laboratory use - Part 031: Safety requirements for hand-held probe assemblies for electrical measurement and test.

Environmental

Restriction of Hazardous Substances (RoHS 2)

The product and its accessories conform to the Directive 2011/65/EU (RoHS 2) on the restriction of the use of certain hazardous substances in electrical and electronic equipment, inclusive of any modification and addendum to said Directive.

EN ISO 63000:2018 Technical documentation for the assessment of electrical and electronic products with respect to the restriction of hazardous substances.



China RoHS 2 refers to the Ministry of Industry and Information Technology Order No. 32, effective July 1, 2015. See "Hazardous Substances Disclosure Table" on page 25.

Product End-of-Life Handling

The equipment may contain substances that could be harmful to the environment or human health if improperly handled at the product's end of life. To avoid release of such substances into the environment and to reduce the use of natural resources, we encourage you to recycle this product to an appropriate system that will ensure that most of the materials are reused or recycled appropriately.



This product is subject to Directive 2012/19/EU of the European Parliament and the Council of the European Union on waste electrical and electronic equipment (WEEE), and in jurisdictions adopting that Directive, is marked as being put on the market after August 13, 2005, and should not be disposed of as unsorted municipal waste. Please utilize your local WEEE collection facilities in the disposition of this product.

Terms & Symbols

The following terms, symbols, and definitions, individually or combination may appear on the product or in this user manual.

Terms

CAUTION A caution statement calls attention to an operating procedure, practice, or condition, which, if not followed correctly, could result in damage to or destruction of parts or the entire product.

MISE EN GARDE Une mise en garde attire l'attention sur une procédure d'exploitation, une pratique ou une condition qui, si elle n'est pas suivie correctement, pourrait entraîner des dommages ou la destruction de pièces ou de l'ensemble du produit.

VORSICHT Ein Warnhinweis macht auf einen Betriebsablauf, eine Vorgehensweise oder einen Betriebszustand aufmerksam, der bei Nichtbeachtung zur Beschädigung oder Zerstörung von Teilen oder des gesamten Produkts führen kann.

WARNING A warning statement calls attention to an operating procedure, practice, or condition, which, if not followed correctly, could result in injury or death to personnel.

AVERTISSEMENT Une déclaration d'avertissement attire l'attention sur une procédure d'exploitation, une pratique ou une condition qui, si elle n'est pas suivie correctement, pourrait entraîner des blessures, voire la mort du personnel.

WARNUNG Ein Warnhinweis macht auf ein Betriebsverfahren, eine Vorgehensweise oder einen Betriebszustand aufmerksam, der bei Nichtbeachtung zu Verletzungen oder zum Tod des Personals führen kann.

NOTE A note statement calls attention to an operating procedure, practice, or condition, which, should be noted before proceeding.

REMARQUE Une note attire l'attention sur une procédure d'exploitation, une pratique ou une condition qui doit être notée avant de continuer.

NOTIZ Eine Hinweiserklärung macht auf einen Betriebsablauf, eine Vorgehensweise oder einen Zustand aufmerksam, der vor dem Fortfahren beachtet werden sollte.

Symbols



CAUTION – Statements or instructions that must be consulted in order to find out the nature of the potential hazard and any actions which must be taken.



WARNING - HIGH VOLTAGE - possibility of electric shock.



Earth (ground) TERMINAL - Refer to the instructions accompanying this symbol in this manual.



The Conformité Européenne (CE) mark is the European Union's (EU) mandatory conformity marking for regulating the goods sold within the European Economic Area (EEA).

Safety Information

Safety Notices

These test probes have been designed and tested in accordance with accepted industry standards and has been supplied in a safe condition. Before applying power, verify that the correct safety precautions are taken (see the following warnings). In addition, note the external markings on the instrument that are described under “Symbols” on page 6.

Throughout this manual and specifically in this section, there are warnings, cautions, and notes that you must follow to ensure safe operation and to maintain the probe in a safe condition.

WARNING To avoid personal injury and to prevent fire or damage to the probe and the products connected to it, review and comply with the following safety Warning and Cautions.

AVERTISSEMENT Pour éviter les blessures corporelles et pour éviter un incendie ou des dommages à la sonde et aux produits qui y sont connectés, lisez et respectez les avertissements et mises en garde de sécurité suivants.

WARNUNG Um Verletzungen zu vermeiden und Brände oder Schäden an der Sonde und den daran angeschlossenen Produkten zu verhindern, lesen und befolgen Sie die folgenden Sicherheitswarnungen und Vorsichtsmaßnahmen.

WARNING Do not use your probe in a manner not specified by the manufacturer. Be aware, that if used in a manner not specified by the manufacturer, the protection provided by the probe assembly may be impaired.

AVERTISSEMENT N'utilisez pas votre sonde d'une manière non spécifiée par le fabricant. Sachez que si elle est utilisée d'une manière non spécifiée par le fabricant, la protection fournie par l'ensemble de sonde peut être altérée.

WARNUNG Verwenden Sie Ihre Sonde nicht auf eine Weise, die nicht vom Hersteller angegeben ist. Beachten Sie, dass der durch die Sondenbaugruppe gebotene Schutz beeinträchtigt werden kann, wenn der Sensor nicht auf eine vom Hersteller angegebene Weise verwendet wird.

WARNING The Probe Must be Grounded:



Before making connections to the input leads of the probe, ensure that the output BNC cable is attached to the BNC input channel of the oscilloscope AND the oscilloscope is properly grounded.

When measuring high-voltages greater than ± 10 kV DC or 5 kVrms, the separate ground lead (GND) must be connected to an established earth ground.

AVERTISSEMENT La sonde doit être mise à la terre:



Avant d'effectuer les connexions aux fils d'entrée de la sonde, assurez-vous que le câble de sortie BNC est connecté au canal d'entrée BNC de l'oscilloscope ET que l'oscilloscope est correctement mis à la terre.

Lors de la mesure de hautes tensions supérieures à ± 10 kV DC ou 5 kVrms, le fil de terre séparé (GND) doit être connecté à une terre établie.

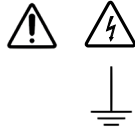
WARNUNG

Die Sonde muss geerdet sein:

Bevor Sie Verbindungen zu den Eingangsleitungen des Tastkopfes herstellen, stellen Sie sicher, dass das BNC-Ausgangskabel an den BNC-Eingangskanal des Oszilloskops angeschlossen ist UND das Oszilloskop ordnungsgemäß geerdet ist.

Bei der Messung von Hochspannungen über ± 10 kV DC oder 5 kVrms muss die separate Erdungsleitung (GND) an eine etablierte Erdung angeschlossen werden.

WARNUNG

Connect and Disconnect the Probe Properly.

Connect the probe to the oscilloscope before connecting the probe inputs to the circuit under test. Disconnect the probe inputs from the circuit under test before disconnecting the probe from the oscilloscope.

AVERTISSEMENT

Connectez et déconnectez la sonde correctement.

Connectez la sonde à l'oscilloscope avant de connecter les entrées de la sonde au circuit testé. Déconnectez les entrées de la sonde du circuit testé avant de déconnecter la sonde de l'oscilloscope.

WARNUNG

Schließen Sie die Sonde ordnungsgemäß an und trennen Sie sie.

Schließen Sie den Tastkopf an das Oszilloskop an, bevor Sie die Tastkopfeingänge an den zu prüfenden Schaltkreis anschließen. Trennen Sie die Tastkopfeingänge vom zu prüfenden Schaltkreis, bevor Sie den Tastkopf vom Oszilloskop trennen.

WARNUNG

Observe Maximum Working Voltages.

To avoid injury, do not use the probes above 1000 Vrms in a CAT III environment between each input lead and earth or between the two input leads.

AVERTISSEMENT

Respectez les tensions de fonctionnement maximales.

Pour éviter les blessures, n'utilisez pas les sondes au-dessus de 1 000 Vrms dans un environnement CAT III entre chaque fil d'entrée et la terre ou entre les deux fils d'entrée.

WARNUNG

Beachten Sie die maximalen Betriebsspannungen.

Um Verletzungen zu vermeiden, verwenden Sie die Tastköpfe nicht über 1000 Vrms in einer CAT III-Umgebung zwischen jedem Eingangskabel und Erde oder zwischen den beiden Eingangskabeln.

WARNUNG

Do not hold probe in hand when measuring voltages over 1000 V.

AVERTISSEMENT

Ne tenez pas la sonde en main lorsque vous mesurez des tensions supérieures à 1000 V.

WARNUNG

Halten Sie die Sonde nicht in der Hand, wenn Sie Spannungen über 1000 V messen.

WARNUNG

Do not operate probe for more than 5 minutes when measuring voltages greater than 10 kV DC or 7 kVrms. Probe must be allowed a 30 minute input resistor cool down after this high-voltage measurement.

AVERTISSEMENT

Ne faites pas fonctionner la sonde pendant plus de 5 minutes lors de la mesure

de tensions supérieures à 10 kV DC ou 7 kVrms. La sonde doit pouvoir refroidir la résistance d'entrée pendant 30 minutes après cette mesure haute tension.

WARNING Betreiben Sie die Sonde nicht länger als 5 Minuten, wenn Sie Spannungen über 10 kV DC oder 7 kVrms messen. Nach dieser Hochspannungsmessung muss der Sonde eine 30-minütige Abkühlung des Eingangswiderstands ermöglicht werden.

WARNING Do not attempt internal service or adjustment.
Do not install substitute parts or perform unauthorized modifications to the probe. Service should be carried out by Cal Test authorized service personnel. For any service needs, contact Cal Test Electronics. Do Not Operate the probe with its case open.

AVERTISSEMENT Ne tentez pas de réparation ou de réglage interne.
N'installez pas de pièces de rechange et n'effectuez pas de modifications non autorisées à la sonde. L'entretien doit être effectué par le personnel de service agréé Cal Test. Pour tout besoin de service, contactez Cal Test Electronics. N'utilisez pas la sonde avec son boîtier ouvert.

WARNING Versuchen Sie nicht, das Gerät selbst zu warten oder anzupassen.
Installieren Sie keine Ersatzteile und nehmen Sie keine unbefugten Änderungen an der Sonde vor. Die Wartung sollte von von Cal Test autorisiertem Servicepersonal durchgeführt werden. Bei Servicebedarf wenden Sie sich bitte an Cal Test Electronics. Betreiben Sie die Sonde nicht mit geöffnetem Gehäuse.

WARNING Avoid Exposed Circuits. To avoid injury, remove jewelry such as rings, watches, and other metallic objects. Do not touch exposed connections and components when power is present.

AVERTISSEMENT Évitez les circuits exposés. Pour éviter les blessures, retirez les bijoux tels que les bagues, les montres et autres objets métalliques. Ne touchez pas les connexions et les composants exposés lorsque l'alimentation est présente.

WARNING Vermeiden Sie freiliegende Schaltkreise. Um Verletzungen zu vermeiden, legen Sie Schmuck wie Ringe, Uhren und andere Metallgegenstände ab. Berühren Sie freiliegende Anschlüsse und Komponenten nicht, wenn Strom vorhanden ist.

WARNING Use Proper Power Source. To ensure the probe function properly, use only the supplied mains adapter. Any input power voltage over 12 V DC will damage the probe.

AVERTISSEMENT Utilisez une source d'alimentation appropriée. Pour garantir le bon fonctionnement de la sonde, utilisez uniquement l'adaptateur secteur fourni. Toute tension d'alimentation d'entrée supérieure à 12 V CC endommagera la sonde.

WARNING Verwenden Sie die richtige Stromquelle. Um eine einwandfreie Funktion der Sonde zu gewährleisten, verwenden Sie ausschließlich das mitgelieferte Netzteil. Jede Eingangsspannung über 12 V DC führt zu Schäden an der Sonde.

WARNING For Indoor Use Only. To avoid electric shock, injury, or fire hazard, do not operate this probe in wet or damp conditions or in an explosive atmosphere.

AVERTISSEMENT Pour une utilisation en intérieur uniquement. Pour éviter les chocs électriques, les blessures ou les risques d'incendie, n'utilisez pas cette sonde dans des conditions humides ou humides ou dans une atmosphère explosive.

WARNUNG Nur zur Verwendung im Innenbereich. Um Stromschläge, Verletzungen oder Brandgefahr zu vermeiden, betreiben Sie diese Sonde nicht in nassen oder feuchten Umgebungen oder in einer explosionsfähigen Atmosphäre.

WARNING Periodically inspect your probe, input lead wires, and output cable, to check for any damage. Do Not Operate with Visible or Suspected Failures. If you suspect there is damage, have it inspected by Cal Test authorized service personnel.

AVERTISSEMENT Inspectez périodiquement votre sonde, vos fils d'entrée et votre câble de sortie pour vérifier tout dommage. Ne pas utiliser avec des pannes visibles ou suspectées. Si vous soupçonnez qu'il y a des dommages, faites-le inspecter par le personnel de service agréé Cal Test.

WARNUNG Überprüfen Sie Ihre Sonde, die Eingangskabel und das Ausgangskabel regelmäßig auf Beschädigungen. Betreiben Sie das Gerät nicht bei sichtbaren oder vermuteten Fehlern. Wenn Sie vermuten, dass ein Schaden vorliegt, lassen Sie ihn von einem von Cal Test autorisierten Servicepersonal untersuchen.

WARNING When it is likely that the ground protection is impaired, you must make the instrument inoperative and secure it against any unintended operation.

AVERTISSEMENT Lorsqu'il est probable que la protection de la terre soit altérée, vous devez rendre l'instrument inopérant et le sécuriser contre toute opération involontaire.

WARNUNG Wenn die Gefahr einer Beeinträchtigung des Bodenschutzes besteht, müssen Sie das Gerät außer Betrieb setzen und es gegen unbeabsichtigten Betrieb sichern.

CAUTION The probe and its cables are sensitive parts and therefore, you should be careful not to damage them though excessive bending or pulling. Avoid any mechanical shocks to the probe to guarantee accurate performance and protection.

MISE EN GARDE La sonde et ses câbles sont des pièces sensibles et vous devez donc faire attention à ne pas les endommager en les pliant ou en les tirant excessivement. Évitez tout choc mécanique sur la sonde pour garantir des performances et une protection précises.

VORSICHT Die Sonde und ihre Kabel sind empfindliche Teile und daher sollten Sie darauf achten, sie nicht durch übermäßiges Biegen oder Ziehen zu beschädigen. Vermeiden Sie mechanische Stöße auf die Sonde, um eine genaue Leistung und Schutz zu gewährleisten.

IEC Measurement Category & Pollution Degree Definitions

Measurement Category (CAT) - classification of testing and measuring circuits according to the types of mains circuits to which they are intended to be connected.

Measurement Category *other than* II, III, or IV: circuits that are not directly connected to the mains supply.

Measurement Category II (CAT II): test and measuring circuits connected directly to utilization points (socket outlets and similar prints) of the low-voltage mains installation..

Measurement Category III (CAT III): test and measuring circuits connected to the distribution part of a building's low-voltage mains installation.

Measurement Category IV (CAT IV): test and measuring circuits connected at the source of the building's low-voltage mains installation.

Mains Isolated: is for measurements performed on circuits not directly connected to a mains supply.

Pollution - addition of foreign matter, solid, liquid, or gaseous (ionized gases) that may produce a reduction of dielectric strength or surface resistivity.

Pollution Degree 2 (P2) - only non-conductive pollution occurs except that occasionally a temporary conductivity caused by condensation is expected.

Introduction

Overview

The Cal Test CT4525 High-Voltage Differential probes allows an earth-grounded oscilloscopes to be used for floating signal measurements up to 40 kVp-p differential or common mode.

The model offers user selectable attenuations of 500x & 5000x, making the probe highly versatile and usable for a broad range of applications including power supply measurements and motor controls.

The probe is compatible with any oscilloscope with a 1 MΩ BNC female input and feature bandwidths of 60 MHz at 500x and 20 MHz at 5000x. The probe kit features a full range of accessories and is powered by an included mains power adapter.

The figure below show some key features of the CT4525 probe.

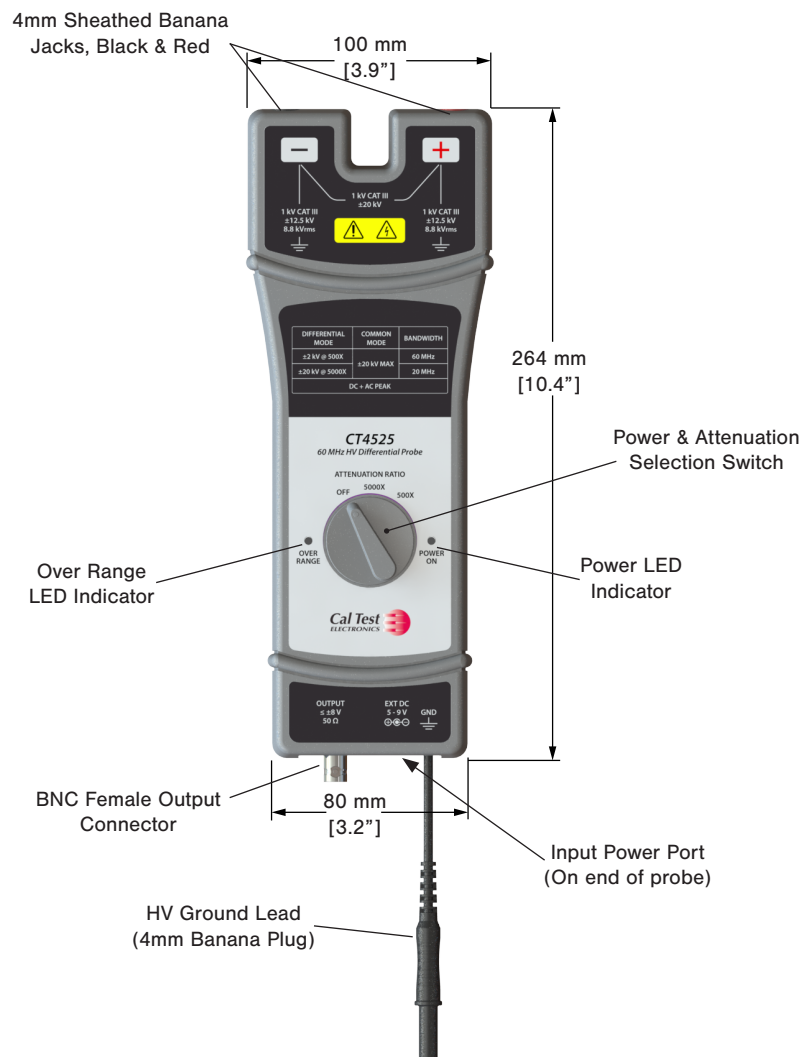

Figure 1 Probe Details

Table 1 Key Features

Features	Description
Power & Attenuation Selection Switch	Selecting an attenuation value turns the unit on.
Power LED Indicator	The Power LED Indicator will illuminate when unit is powered on.
4mm Sheathed Banana Jacks, Black & Red	Signal input jacks. Connect the supplied test leads for signal input.
Over Range LED Indicator	LED will turn red when the unit is in voltage overload condition.
BNC female Output Connector	Connects the probe to an oscilloscope's BNC female input connector using the supplied Insulated BNC cable assembly
Input Power Port (on end of probe)	Insert the supplied Mains Power Adapter's coaxial power plug into the Power Port to power the unit.
HV Ground Lead	Supplemental high-voltage ground connection. Use when measuring voltages over ± 10 kV DC or 5 kVrms.

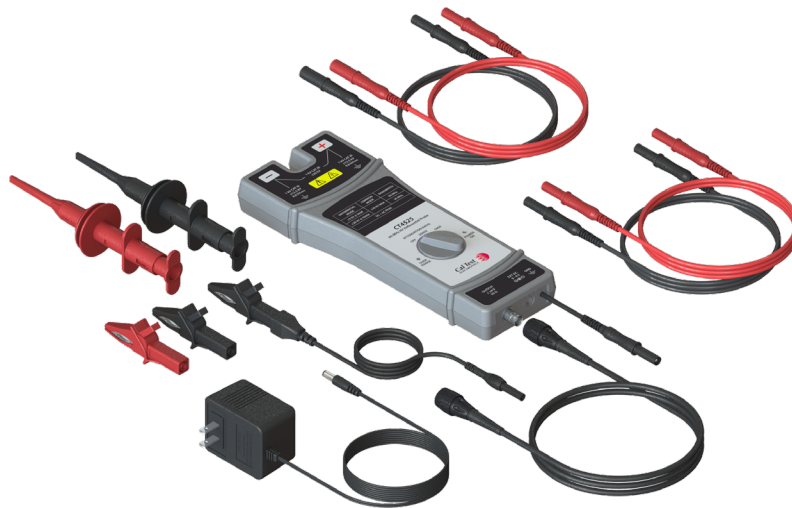





Figure 2 Probe and Supplied Accessories

Supplied Accessories

Table 2 CT4525 Accessories

Accessory		Model No.	Quantity
Insulated BNC male to male Output Cable Assembly, 1 m Length		CT3955-100	1
Insulated HV Sprung Hook Probes, 5 kV, 3 A, Pair (B/R)		CT4402	1
Alligator Ground Clip Lead, 1 m Length		CT4494-85	1
Power Adapter, NA Plugs to 5.5 mm Plug		CT4526	1
Alligator Clip Pair (B/R)		CT4527	1
4mm HV Input Leads, Banana Plug to Banana Plug, 60 cm, Pair (B/R)		CT4528-60	1
4mm HV Extension Leads, Banana Plug to Banana Jack, 100 cm, Pair (B/R)		CT4529-100	1

Setting Up and Using the Probe

WARNING

Before connecting the probe for your measurement, read all the warnings in this section and all of the warnings in the section "Safety Information" starting on page 7.

AVERTISSEMENT

Avant de connecter la sonde pour votre mesure, lisez tous les avertissements de cette section et tous les avertissements de la section « Informations de sécurité » commençant à la page 7.

WARNUNG

Bevor Sie die Sonde für Ihre Messung anschließen, lesen Sie alle Warnhinweise in diesem Abschnitt und alle Warnhinweise im Abschnitt „Sicherheitsinformationen“ ab Seite 7.

Setting Up

1. To use the probe, first plug Power Adapter into mains circuit then insert coax power plug into probe's input jack.
2. Insert the banana plug input leads to the probe's input jack, black and red; then connect the Insulated BNC cable to the probe's output jack and to an input channel connector of the oscilloscope

Using

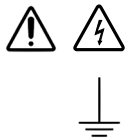
WARNING

The Probe Must be Grounded.

Before making connections to the input leads of the probe, ensure that the output BNC connector is attached to the BNC input channel of the oscilloscope AND the oscilloscope is properly grounded.

When measuring high-voltages greater than ± 10 kV DC or 5 kVrms, the separate ground lead (GND) must be connected to an established earth ground.

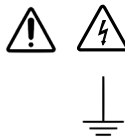
AVERTISSEMENT

La sonde doit être mise à la terre.

Avant d'effectuer les connexions aux fils d'entrée de la sonde, assurez-vous que le connecteur BNC de sortie est connecté au canal d'entrée BNC de l'oscilloscope ET que l'oscilloscope est correctement mis à la terre.

Lors de la mesure de hautes tensions supérieures à ± 10 kV DC ou 5 kVrms, le fil de terre séparé (GND) doit être connecté à une terre établie.

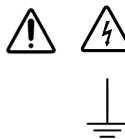
WARNUNG

Die Sonde muss geerdet sein.

Bevor Sie Verbindungen zu den Eingangsleitungen des Tastkopfs herstellen, stellen Sie sicher, dass der BNC-Ausgangsstecker am BNC-Eingangskanal des Oszilloskops angeschlossen ist UND das Oszilloskop ordnungsgemäß geerdet ist.

Bei der Messung von Hochspannungen über ± 10 kV DC oder 5 kVrms muss die separate Erdungsleitung (GND) an eine etablierte Erdung angeschlossen werden.

3. Select the desired attenuation ratio, 500x or 5000x, via the attenuation selection switch.
4. Turn off the high voltage source.
5. Press the HV sprung hooks on its matching color 4mm sheathed banana plug input lead.

-
6. Connect the HV sprung hooks to the circuit under test.

WARNING To protect against electric shock, use only the HV sprung hooks supplied with this probe.

AVERTISSEMENT Pour vous protéger contre les chocs électriques, utilisez uniquement les crochets à ressort HT fournis avec cette sonde.

WARNUNG Verwenden Sie zum Schutz vor Stromschlägen nur die mit dieser Sonde gelieferten HV-Federhaken.

7. After confirming that the probe operator is not touching the device under test, turn on the high-voltage source.

8. Measure the voltage under test and observe the waveform on the oscilloscope.

WARNING Remember the actual voltage is the attenuation factor greater than the oscilloscope waveform.

AVERTISSEMENT N'oubliez pas que la tension réelle correspond au facteur d'atténuation supérieur à la forme d'onde de l'oscilloscope.

WARNUNG Bedenken Sie, dass die tatsächliche Spannung um einen Dämpfungsfaktor größer ist als die Wellenform des Oszilloskops.

WARNING Do not operate probe for more than 5 minutes when measuring voltages greater than 10 kV DC or 7 kVrms. Probe must be allowed a 30 minute input resistor cool down after high-voltage measurements.

AVERTISSEMENT Ne faites pas fonctionner la sonde pendant plus de 5 minutes lors de la mesure de tensions supérieures à 10 kV DC ou 7 kVrms. La sonde doit pouvoir refroidir la résistance d'entrée pendant 30 minutes après les mesures haute tension.

WARNUNG Betreiben Sie die Sonde nicht länger als 5 Minuten, wenn Sie Spannungen über 10 kV DC oder 7 kVrms messen. Nach Hochspannungsmessungen muss der Sonde eine 30-minütige Abkühlung des Eingangswiderstands ermöglicht werden.

9. Turn off high voltage source.

10. Disconnect the probe inputs from the high-voltage source.

Specifications & Characteristics

The probe and oscilloscope should be warmed up for at least 20 minutes before any testing and the environmental conditions should not exceed the probe's specified limits.

NOTE

All entries included in the following tables are characteristics unless otherwise stated.

REMARQUE

Toutes les entrées incluses dans les tableaux suivants sont des caractéristiques, sauf indication contraire.

NOTIZ

Alle in den folgenden Tabellen enthaltenen Einträge sind Merkmale, sofern nicht anders angegeben.

Table 3 Safety Specifications

Parameter	Condition
IEC/EN 61010-031:2015	Measurement Category III

Table 4 Electrical Specifications (Not Warranted)

Parameter	CT4525
Bandwidth (-3 dB)	60 MHz @ 500x 20 MHz @ 5000x
Gain Accuracy	±2%
Attenuation Ratio	500x / 5000x
Rise Time	17 ns @ 500x 50 ns @ 5000x
Absolute Maximum Rated Input Voltage (each side to ground)	1000 V CAT III ±12.5 kV DC ±8.8 kVrms
Maximum Differential Input Voltage (DC + AC Peak)	1000 V CAT III ±12.5 kV DC ±8.8 kVrms
Maximum Common Mode Input Voltage (DC + AC Peak)	±20 kV @ 500x ±20 kV @ 5000x
Input Impedance	140 MΩ // 3 pF (differential) 280 MΩ // 1.5 pF (each side to ground)
Output Voltage	±5 V (driving 1 MΩ load)
Offset (typical)	±20 mV
Noise (typical)	0.7 mVrms
CMRR (typical)	60 Hz: ≥80 dB 100 Hz: ≥60 dB 1 MHz: ≥50 dB

Power Supply - Mains Adapter (NA Plugs)	Input: 110 V AC 50 Hz Output: 9 V DC, 300 mA
Power Consumption	120 mA max. (1.1 W)

Table 5 Mechanical Specifications

Parameter	Characteristic
Input Jacks (each)	4mm Sheathed Banana Jacks (Black and Red)
Dimension (L x W x H)	100 mm x 264 mm x 34 mm
Weight	488 g (1.07 lb)
Ground Plug Length	10 cm ±3 cm

Table 6 Environmental Specifications

Parameter	Characteristic
Operating Temperature	0°C to 50°C (32°F to 122°F)
Storage Temperature	-30°C to 70°C (-22°F to 158°F)
Humidity	≤ 80% RH @ 25°C to 35°C (77°F to 95°F)
Altitude	Operating: 2000 m Non-operating: 15000 m
Pollution Degree	P2

Performance Plots

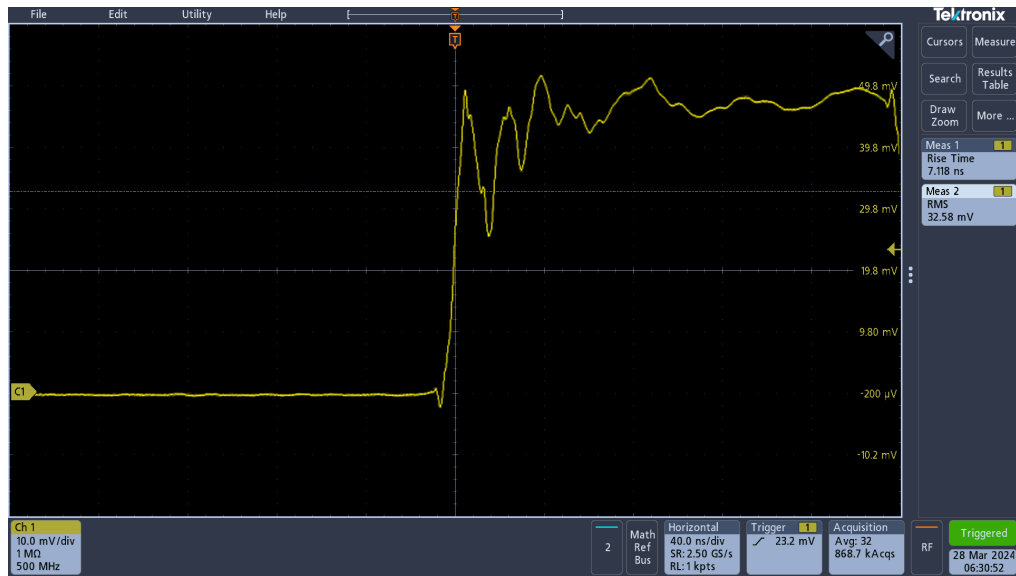

Figure 3 Rise Time

500x attenuation, 10%-90%

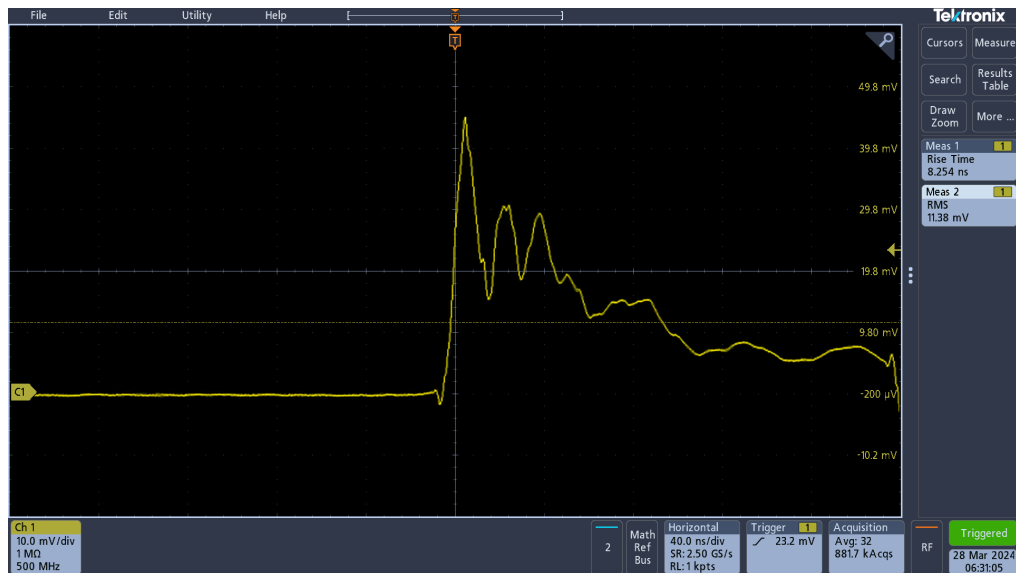

Figure 4 Rise Time

5000x attenuation, 10%-90%

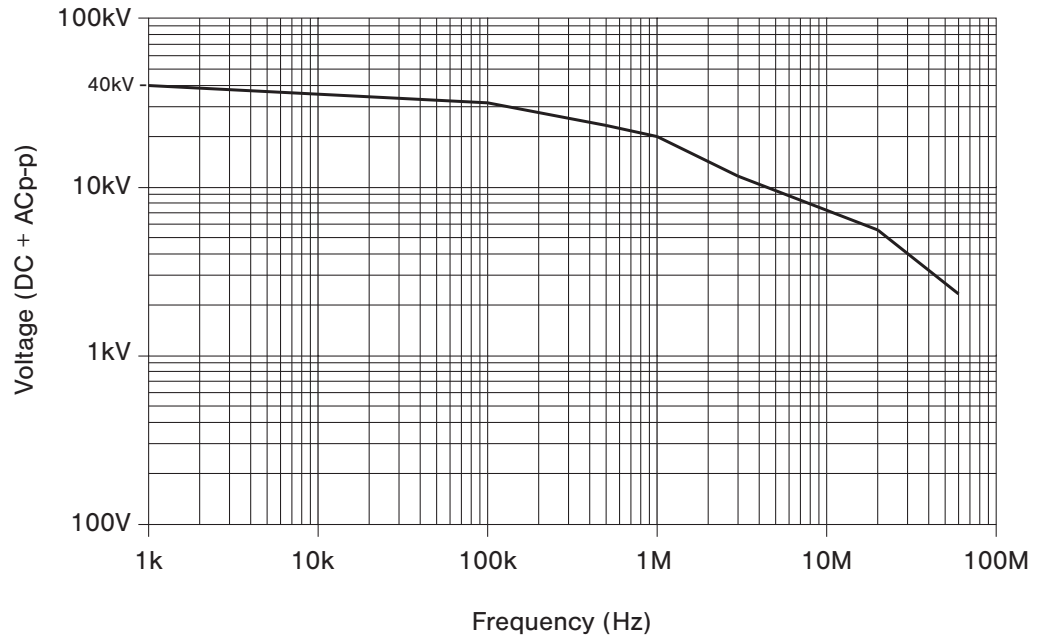

Figure 5 Typical Voltage Derating

Typical derating plot of the absolute maximum input voltage in common mode.

Inflection Points:

40 kVp-p @ 1 kHz / 32 kVp-p @ 100 kHz / 24 kVp-p @ 1 MHz / 20 kVp-p @ 10 MHz / 12 kVp-p @ 30 MHz / 5.6 kVp-p @ 60 MHz / 2.4 kVp-p @ 60 MHz

Performance Verification

Required Equipment

The following procedures can be used to test the differential gain accuracy and rise time. Please note that these procedures do not indicate that the characteristics are warranted. They are meant to indicate the probe is functioning properly.

NOTE Allow the probe to warm up at least 20 minutes.

REMARQUE Laissez la sonde se réchauffer pendant au moins 20 minutes.

NOTIZ Lassen Sie die Sonde mindestens 20 Minuten aufwärmen.

Table 7 Required Test Equipment (Inaddition to the probe's accessories)

Description	Minimum Requirements	Recommended Product
Oscilloscope	Bandwidth: ≥ 500 MHz, 1 M Ω /50 Ω selectable inputs	Tektronix MDO32
Generator/Calibrator	≥ 20 V variable amplitude, 100 Hz square wave, calibrated	Fluke 5522A
Pulse Generator	≥ 50 V, 200 ns, ≤ 500 ps RT	Avtech AVR E2-B
Digital Multimeter (DMM)	100 mV and 1 V True RMS AC ranges, $\leq \pm 0.3\%$ Accuracy	B&K 5493C
Coax cable	BNC male to BNC male, 50 Ω , 1 m (2)	Cal Test CT4098-100
Adapter	BNC female to 4 mm double banana plugs	Cal Test CT2939
Adapter	BNC female to SMA male	Cal Test CT3316
Adapter	BNC female to female	Cal Test CT2765
Adapter	BNC male to 4 mm double sheathed banana jacks	Cal Test CT2412
Adapter	4 mm banana plug to jack, pair (black & red)	Cal Test CT3089
Terminator	BNC male to female feed-thru, 50 Ω	Cal Test CT2944C-50
Attenuator	BNC male to female, 50 Ω , 6 dB (2x)	Cal Test CT3369A-06

Test Procedures

Test Setup

1. Turn on the oscilloscope.
2. Connect the probe to any channel on the oscilloscope (for warm-up).
3. Connect the AC power adapter to mains line voltage.
4. Turn on the probe and verify the Power On LED.
5. Turn on the remaining test equipment and let the probe and equipment warm up for a minimum of 20 minutes.

Gain Accuracy

WARNING Dangerous voltages will be present on the generator/calibrator output terminals and connection cables. Always verify that the generator/calibrator is in the standby mode before you make any connections to the generator.

AVERTISSEMENT Des tensions dangereuses seront présentes sur les bornes de sortie du générateur/calibrateur et sur les câbles de connexion. Vérifiez toujours que le générateur/calibrateur est en mode veille avant d'effectuer des connexions au générateur.

WARNUNG An den Ausgangsklemmen und Verbindungskabeln des Generators/Kalibrierers liegen gefährliche Spannungen an. Stellen Sie immer sicher, dass sich der Generator/Kalibrator im Standby-Modus befindet, bevor Sie Verbindungen zum Generator herstellen.

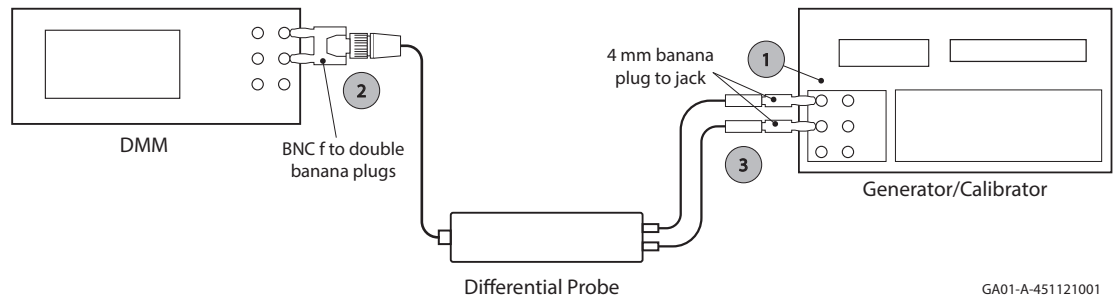

1. Verify that the generator/calibrator output is in standby.
2. Connect the probe output directly to the DMM through the BNC female to 4 mm double banana plugs adapter.
3. Connect the probe's input leads to the generator/calibrator outputs using banana plug adapters.
4. Set the DMM to AC volts.
5. Set the probe's attenuation range and the generator/calibrator to square wave output, frequency and RMS voltage to the values, show in table below, for the probe being tested.
6. Enable the generator/calibrator output and record the probe output (as displayed on the DMM) in the table.
7. Place the generator/calibrator output in standby.
8. Set the probe attenuation to the next range and repeat steps 5 through 8.
9. Shutdown test equipment when done.

Table 8 Gain Accuracy Equipment Setting

Model	Probe	Generator/Calibrator		Probe Output	
	Range	Voltage	Frequency	Expected (rms)	Measured (rms)
CT4525	500x	50 Vrms	100 Hz	100 mV \pm 2 mV	
	5000x	50 Vrms	100 Hz	10 mV \pm 0.2 mV	

Rise Time

1. Verify that the pulse generator output is off and then connect the probe to the oscilloscope input channel.
2. Connect the probe inputs, through the adapters shown below, to the pulse generator output. Set the probe input leads straight and parallel for best signal response.

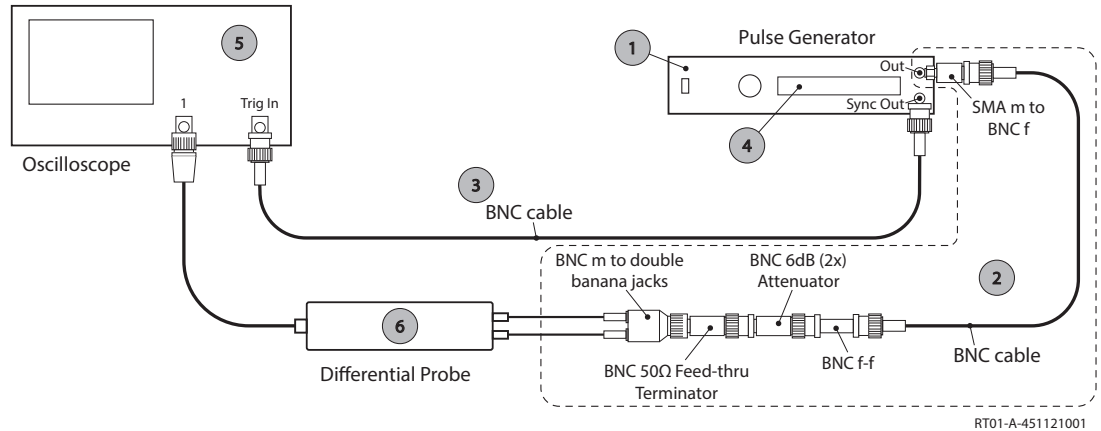

3. Connect pulse generator output trigger to oscilloscope trigger input.
4. Set the output of the pulse generator to 50 V, 1 kHz, and 200 ns pulse output. (Note: the probe input voltage will be 25 V due to the 6 dB (2x) attenuator in the circuit.)
5. Set the oscilloscope to 5 V/div, 10 ns/div, BW = full, average = 16.
6. Set the probe attenuation to the first range listed in the table below.
7. Enable the pulse generator output and check that the rise time does not exceed the expected rise time value listed in the table. Use the auto-measure feature of the oscilloscope to determine the rise time.
8. Record the rise time in the table below.
9. Set the probe attenuation to the next range and adjust the vertical volts/div to display the signal.
10. Record the rise time in the table below and disable the pulse generator output.
11. Shutdown test equipment when done.

Table 9 Rise Time Test Equipment Settings

Model	Probe	Pulse Generator Output		Probe Output	
	Range	Voltage	Frequency	Expected (ns)	Measured (ns)
CT4525	500x	50 V	1 kHz	≤17 ns	
	5000x	50 V	1 kHz	≤17 ns	

Cleaning

Clean only the exterior probe body and cables. Use a soft cotton cloth light moistened with a mild solution of detergent and water. Do not allow any portion of the probe to be submerged at any time.

WARNING Dry the probe thoroughly before attempting to make voltage measurements.

AVERTISSEMENT Séchez soigneusement la sonde avant de tenter d'effectuer des mesures de tension.

WARNUNG Trocknen Sie die Sonde gründlich ab, bevor Sie versuchen, Spannungsmessungen durchzuführen.

CAUTION Do not subject the probe to solvents or solvent fumes as these can cause deterioration of the probe body and cables.

MISE EN GARDE Ne soumettez pas la sonde à des solvants ou à des vapeurs de solvants car ceux-ci peuvent entraîner une détérioration du corps de la sonde et des câbles.

VORSICHT Setzen Sie die Sonde keinen Lösungsmitteln oder Lösungsmitteldämpfen aus, da diese zu einer Beschädigung des Sondengehäuses und der Kabel führen können.

China RoHS 2

Hazardous Substances Disclosure Table



China RoHS 2 refers to the Ministry of Industry and Information Technology Order No. 32, effective July 1, 2015, titled Management Methods for the Restriction of the Use of Hazardous Substances in Electrical and Electronic Products. To comply with China RoHS 2, we determined this product's Environmental Protection Use Period (EPUP) to be 25 years in accordance with the Marking for the Restricted Use of Hazardous Substances in Electronic and Electrical Products, SJ/T 11364.

中國 RoHS 2 指工業和信息化部令第 32 號，自 2015 年 7 月 1 日起生效，題為《電氣電子產品有害物質限制使用管理辦法》。為符合中國 RoHS 2，我們根據電子電氣產品有害物質限制使用標誌 SJ/T 11364 將本產品的環保使用期限 (EPUP) 確定為 25 年。

Part Name 零件名稱	Hazardous Substance 有害物質					
	Lead (Pb) 鉛	Mercury (Hg) 汞	Cadmium (Cd) 鎘	Hexavalent Chromium (Cr (VI)) 六價鉻	Polybrominated biphenyls (PBB) 多溴聯苯	Polybrominated diphenyl ethers (PBDE) 多溴二苯醚
Printed Circuit Board Assemblies 印刷電路板組件	X	O	O	O	O	O
Electrical Components 電氣元件	X	O	O	O	O	O
Metal Components 金屬部件	X	O	O	O	O	O
Plastic Components 塑料部件	O	O	O	O	O	O

This table is made per guidance of SJ/T 11364.
該表是根據 SJ/T 11364 的指南製作的。

O: Indicates that this hazardous substance contained in all of the homogeneous materials for the part is below the limit requirement in GB/T 26572.
O: 表示該有害物質在該部件的所有均質材料中的含量低於 GB/T 26572 中的限量要求。

X: Indicates that this hazardous substance contained in at least one of the homogeneous materials used for this part is above the limit requirement in GB/T 26572.
X: 表示該有害物質在用於該部件的至少一種均質材料中的含量高於 GB/T 26572 中的限量要求。



© Cal Test Electronics, Inc.
Electronic Format Only
Manual Part Number: 451-121-001
Revision: B

